

**Problem 2.3-8** A bar  $ABC$  of length  $L$  consists of two parts of equal lengths but different diameters (see figure). Segment  $AB$  has diameter  $d_1 = 100$  mm and segment  $BC$  has diameter  $d_2 = 60$  mm. Both segments have length  $L/2 = 0.6$  m. A longitudinal hole of diameter  $d$  is drilled through segment  $AB$  for one-half of its length (distance  $L/4 = 0.3$  m). The bar is made of plastic having modulus of elasticity  $E = 4.0$  GPa. Compressive loads  $P = 110$  kN act at the ends of the bar.

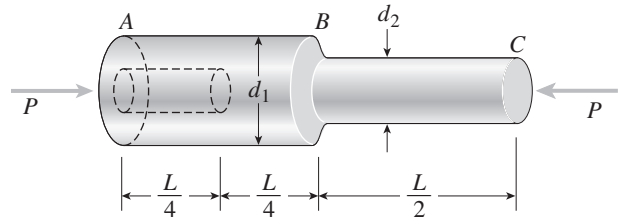

If the shortening of the bar is limited to 8.0 mm, what is the maximum allowable diameter  $d_{max}$  of the hole?

**Solution 2.3-8 Bar with a hole**

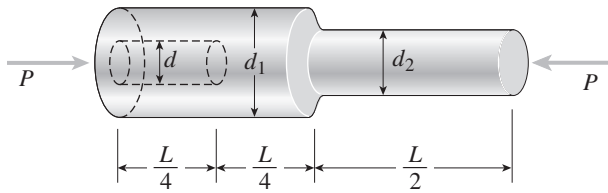

$d$  = diameter of hole

SHORTENING  $\delta$  OF THE BAR

$$\delta = \sum \frac{N_i L_i}{E_i A_i} = \frac{P}{E} \sum \frac{L_i}{A_i}$$

$$= \frac{P}{E} \left[ \frac{L/4}{\frac{\pi}{4}(d_1^2 - d^2)} + \frac{L/4}{\frac{\pi}{4}d_1^2} + \frac{L/2}{\frac{\pi}{4}d_2^2} \right]$$

$$= \frac{PL}{\pi E} \left( \frac{1}{d_1^2 - d^2} + \frac{1}{d_1^2} + \frac{2}{d_2^2} \right) \quad (\text{Eq. 1})$$

NUMERICAL VALUES (DATA):

$\delta$  = maximum allowable shortening of the bar  
= 8.0 mm

$P = 110$  kN     $L = 1.2$  m     $E = 4.0$  GPa

$d_1 = 100$  mm

$d_{max}$  = maximum allowable diameter of the hole

$d_2 = 60$  mm

SUBSTITUTE NUMERICAL VALUES INTO EQ. (1) FOR  $\delta$   
AND SOLVE FOR  $d = d_{max}$ :

UNITS: Newtons and meters

$$0.008 = \frac{(110,000)(1.2)}{\pi(4.0 \times 10^9)}$$

$$\times \left[ \frac{1}{(0.1)^2 - d^2} + \frac{1}{(0.1)^2} + \frac{2}{(0.06)^2} \right]$$

$$761.598 = \frac{1}{0.01 - d^2} + \frac{1}{0.01} + \frac{2}{0.0036}$$

$$\frac{1}{0.01 - d^2} = 761.598 - 100 - 555.556 = 106.042$$

$$d^2 = 569.81 \times 10^{-6} \text{ m}^2$$

$$d = 0.02387 \text{ m}$$

$$d_{max} = 23.9 \text{ mm} \quad \leftarrow$$

**Problem 2.3-9** A wood pile, driven into the earth, supports a load  $P$  entirely by friction along its sides (see figure). The friction force  $f$  per unit length of pile is assumed to be uniformly distributed over the surface of the pile. The pile has length  $L$ , cross-sectional area  $A$ , and modulus of elasticity  $E$ .

- (a) Derive a formula for the shortening  $\delta$  of the pile in terms of  $P$ ,  $L$ ,  $E$ , and  $A$ .
- (b) Draw a diagram showing how the compressive stress  $\sigma_c$  varies throughout the length of the pile.

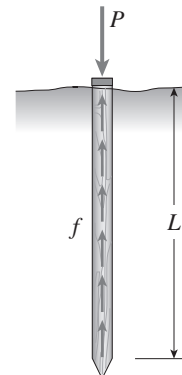

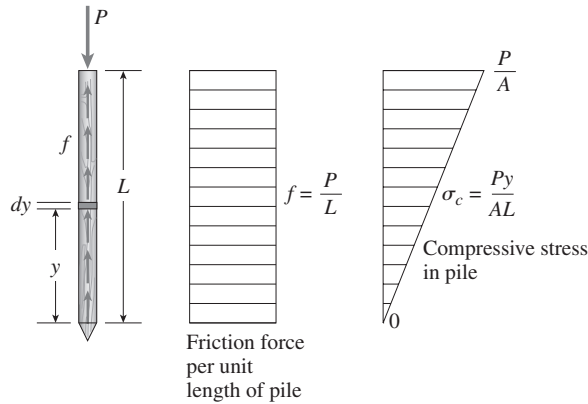
**Solution 2.3-9 Wood pile with friction**

FROM FREE-BODY DIAGRAM OF PILE:

$$\Sigma F_{\text{vert}} = 0 \quad \uparrow + \quad \downarrow - \quad fL - P = 0 \quad f = \frac{P}{L} \quad (\text{Eq. 1})$$

(a) SHORTENING  $\delta$  OF PILE:

At distance  $y$  from the base:

$$N(y) = \text{axial force} \quad N(y) = fy \quad (\text{Eq. 2})$$

$$d\delta = \frac{N(y) dy}{EA} = \frac{fy dy}{EA}$$

$$\delta = \int_0^L d\delta = \frac{f}{EA} \int_0^L y dy = \frac{fL^2}{2EA} = \frac{PL}{2EA}$$

$$\delta = \frac{PL}{2EA} \quad \leftarrow$$

(b) COMPRESSIVE STRESS  $\sigma_c$  IN PILE

$$\sigma_c = \frac{N(y)}{A} = \frac{fy}{A} = \frac{Py}{AL} \quad \leftarrow$$

At the base ( $y = 0$ ):  $\sigma_c = 0$

At the top ( $y = L$ ):  $\sigma_c = \frac{P}{A}$

See the diagram above.

**Problem 2.3-10** A prismatic bar  $AB$  of length  $L$ , cross-sectional area  $A$ , modulus of elasticity  $E$ , and weight  $W$  hangs vertically under its own weight (see figure).

- Derive a formula for the downward displacement  $\delta_C$  of point  $C$ , located at distance  $h$  from the lower end of the bar.
- What is the elongation  $\delta_B$  of the entire bar?
- What is the ratio  $\beta$  of the elongation of the upper half of the bar to the elongation of the lower half of the bar?

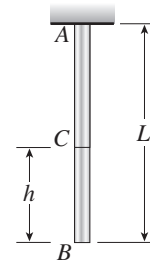
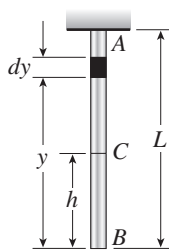
**Solution 2.3-10 Prismatic bar hanging vertically**

$W =$  Weight of bar

(a) DOWNWARD DISPLACEMENT  $\delta_C$

Consider an element at distance  $y$  from the lower end.

$$N(y) = \frac{Wy}{L} \quad d\delta = \frac{N(y)dy}{EA} = \frac{Wydy}{EAL}$$

$$\delta_C = \int_h^L d\delta = \int_h^L \frac{Wydy}{EAL} = \frac{W}{2EAL} (L^2 - h^2)$$

$$\delta_C = \frac{W}{2EAL} (L^2 - h^2) \quad \leftarrow$$

(b) ELONGATION OF BAR ( $h = 0$ )

$$\delta_B = \frac{WL}{2EA} \quad \leftarrow$$

(c) RATIO OF ELONGATIONS

Elongation of upper half of bar ( $h = \frac{L}{2}$ ):

$$\delta_{\text{upper}} = \frac{3WL}{8EA}$$

Elongation of lower half of bar:

$$\delta_{\text{lower}} = \delta_B - \delta_{\text{upper}} = \frac{WL}{2EA} - \frac{3WL}{8EA} = \frac{WL}{8EA}$$

$$\beta = \frac{\delta_{\text{upper}}}{\delta_{\text{lower}}} = \frac{3/8}{1/8} = 3 \quad \leftarrow$$

**Problem 2.3-11** A flat bar of rectangular cross section, length  $L$ , and constant thickness  $t$  is subjected to tension by forces  $P$  (see figure). The width of the bar varies linearly from  $b_1$  at the smaller end to  $b_2$  at the larger end. Assume that the angle of taper is small.

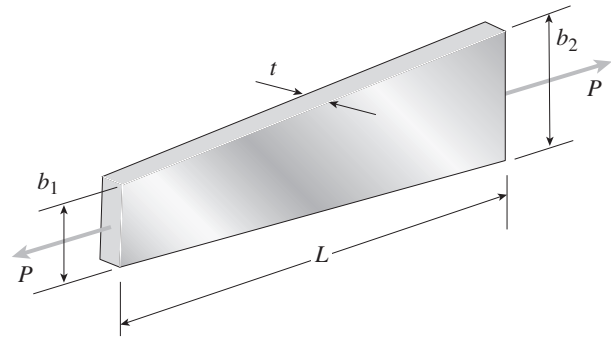

- (a) Derive the following formula for the elongation of the bar:

$$\delta = \frac{PL}{Et(b_2 - b_1)} \ln \frac{b_2}{b_1}$$

- (b) Calculate the elongation, assuming  $L = 5$  ft,  $t = 1.0$  in.,  $P = 25$  k,  $b_1 = 4.0$  in.,  $b_2 = 6.0$  in., and  $E = 30 \times 10^6$  psi.

**Solution 2.3-11 Tapered bar (rectangular cross section)**

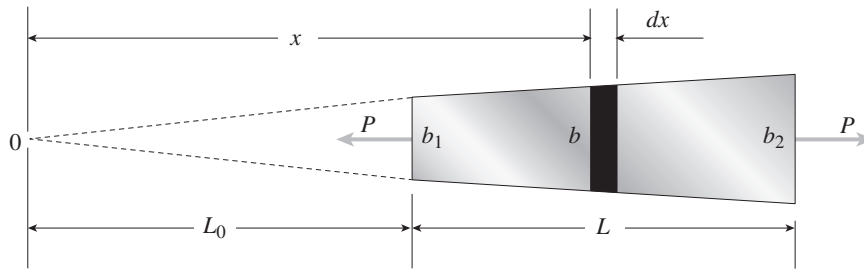

$t =$  thickness (constant)

$$b = b_1 \left( \frac{x}{L_0} \right) \quad b_2 = b_1 \left( \frac{L_0 + L}{L_0} \right) \quad (\text{Eq. 1})$$

$$A(x) = bt = b_1 t \left( \frac{x}{L_0} \right)$$

(a) ELONGATION OF THE BAR

$$d\delta = \frac{Pdx}{EA(x)} = \frac{PL_0 dx}{Eb_1 t x}$$

$$\delta = \int_{L_0}^{L_0+L} d\delta = \frac{PL_0}{Eb_1 t} \int_{L_0}^{L_0+L} \frac{dx}{x}$$

$$= \frac{PL_0}{Eb_1 t} \ln x \Big|_{L_0}^{L_0+L} = \frac{PL_0}{Eb_1 t} \ln \frac{L_0 + L}{L_0} \quad (\text{Eq. 2})$$

$$\text{From Eq. (1): } \frac{L_0 + L}{L_0} = \frac{b_2}{b_1} \quad (\text{Eq. 3})$$

$$\text{Solve Eq. (3) for } L_0: \quad L_0 = L \left( \frac{b_1}{b_2 - b_1} \right) \quad (\text{Eq. 4})$$

Substitute Eqs. (3) and (4) into Eq. (2):

$$\delta = \frac{PL}{Et(b_2 - b_1)} \ln \frac{b_2}{b_1} \quad \leftarrow \quad (\text{Eq. 5})$$

(b) SUBSTITUTE NUMERICAL VALUES:

$$L = 5 \text{ ft} = 60 \text{ in.} \quad t = 10 \text{ in.}$$

$$P = 25 \text{ k} \quad b_1 = 4.0 \text{ in.}$$

$$b_2 = 6.0 \text{ in.} \quad E = 30 \times 10^6 \text{ psi}$$

$$\text{From Eq. (5): } \delta = 0.010 \text{ in.} \quad \leftarrow$$

**Problem 2.3-12** A post  $AB$  supporting equipment in a laboratory is tapered uniformly throughout its height  $H$  (see figure). The cross sections of the post are square, with dimensions  $b \times b$  at the top and  $1.5b \times 1.5b$  at the base.

Derive a formula for the shortening  $\delta$  of the post due to the compressive load  $P$  acting at the top. (Assume that the angle of taper is small and disregard the weight of the post itself.)

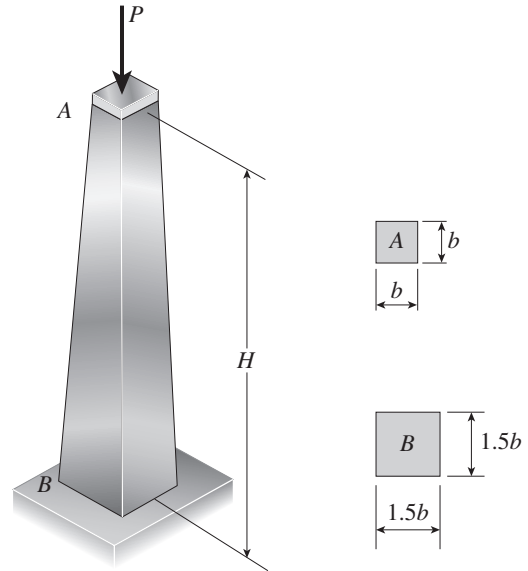

**Solution 2.3-12 Tapered post**

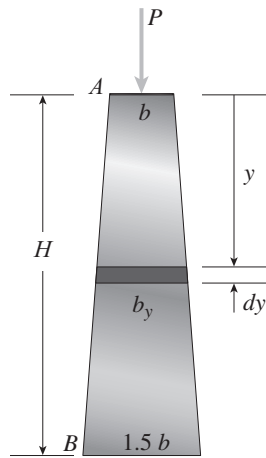

Square cross sections

$$b = \text{width at } A$$

$$1.5b = \text{width at } B$$

$$b_y = \text{width at distance } y$$

$$= b + (1.5b - b)\frac{y}{H}$$

$$= \frac{b}{H}(H + 0.5y)$$

$A_y =$  cross-sectional area at distance  $y$

$$= (b_y)^2 = \frac{b^2}{H^2}(H + 0.5y)^2$$

SHORTENING OF ELEMENT  $dy$

$$d\delta = \frac{Pdy}{EA_y} = \frac{Pdy}{E\left(\frac{b^2}{H^2}\right)(H + 0.5y)^2}$$

SHORTENING OF ENTIRE POST

$$\delta = \int d\delta = \frac{PH^2}{Eb^2} \int_0^H \frac{dy}{(H + 0.5y)^2}$$

$$\text{From Appendix C: } \int \frac{dx}{(a + bx)^2} = -\frac{1}{b(a + bx)}$$

$$\begin{aligned} \delta &= \frac{PH^2}{Eb^2} \left[ -\frac{1}{(0.5)(H + 0.5y)} \right]_0^H \\ &= \frac{PH^2}{Eb^2} \left[ -\frac{1}{(0.5)(1.5H)} + \frac{1}{0.5H} \right] \\ &= \frac{2PH}{3Eb^2} \quad \leftarrow \end{aligned}$$

**Problem 2.3-13** A long, slender bar in the shape of a right circular cone with length  $L$  and base diameter  $d$  hangs vertically under the action of its own weight (see figure). The weight of the cone is  $W$  and the modulus of elasticity of the material is  $E$ .

Derive a formula for the increase  $\delta$  in the length of the bar due to its own weight. (Assume that the angle of taper of the cone is small.)

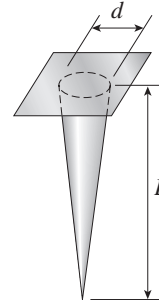

**Solution 2.3-13 Conical bar hanging vertically**

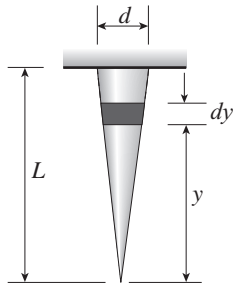

ELEMENT OF BAR

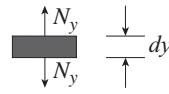

$W$  = weight of cone

TERMINOLOGY

$N_y$  = axial force acting on element  $dy$

$A_y$  = cross-sectional area at element  $dy$

$A_B$  = cross-sectional area at base of cone

$$= \frac{\pi d^2}{4}$$

$V$  = volume of cone

$$= \frac{1}{3} A_B L$$

$V_y$  = volume of cone below element  $dy$

$$= \frac{1}{3} A_y y$$

$W_y$  = weight of cone below element  $dy$

$$= \frac{V_y}{V} (W) = \frac{A_y y W}{A_B L}$$

$N_y = W_y$

ELONGATION OF ELEMENT  $dy$

$$d\delta = \frac{N_y dy}{E A_y} = \frac{W_y dy}{E A_B L} = \frac{4W}{\pi d^2 E L} y dy$$

ELONGATION OF CONICAL BAR

$$\delta = \int d\delta = \frac{4W}{\pi d^2 E L} \int_0^L y dy = \frac{2WL}{\pi d^2 E} \leftarrow$$

**Problem 2.3-14** A bar  $ABC$  revolves in a horizontal plane about a vertical axis at the midpoint  $C$  (see figure). The bar, which has length  $2L$  and cross-sectional area  $A$ , revolves at constant angular speed  $\omega$ . Each half of the bar ( $AC$  and  $BC$ ) has weight  $W_1$  and supports a weight  $W_2$  at its end.

Derive the following formula for the elongation of one-half of the bar (that is, the elongation of either  $AC$  or  $BC$ ):

$$\delta = \frac{L^2 \omega^2}{3gEA} (W_1 + 3W_2)$$

in which  $E$  is the modulus of elasticity of the material of the bar and  $g$  is the acceleration of gravity.

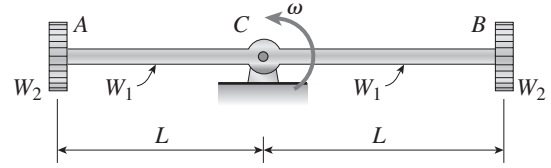

### Solution 2.3-14 Rotating bar

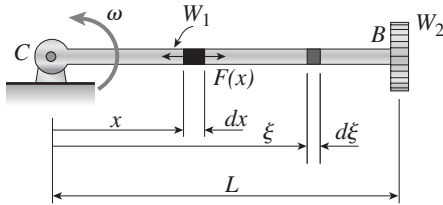

$\omega$  = angular speed

$A$  = cross-sectional area

$E$  = modulus of elasticity

$g$  = acceleration of gravity

$F(x)$  = axial force in bar at distance  $x$  from point  $C$

Consider an element of length  $dx$  at distance  $x$  from point  $C$ .

To find the force  $F(x)$  acting on this element, we must find the inertia force of the part of the bar from distance  $x$  to distance  $L$ , plus the inertia force of the weight  $W_2$ .

Since the inertia force varies with distance from point  $C$ , we now must consider an element of length  $d\xi$  at distance  $\xi$ , where  $\xi$  varies from  $x$  to  $L$ .

$$\text{Mass of element } d\xi = \frac{d\xi}{L} \left( \frac{W_1}{g} \right)$$

$$\text{Acceleration of element} = \xi \omega^2$$

Centrifugal force produced by element

$$= (\text{mass})(\text{acceleration}) = \frac{W_1 \omega^2}{gL} \xi d\xi$$

Centrifugal force produced by weight  $W_2$

$$= \left( \frac{W_2}{g} \right) (L \omega^2)$$

AXIAL FORCE  $F(x)$

$$\begin{aligned} F(x) &= \int_{\xi=x}^{\xi=L} \frac{W_1 \omega^2}{gL} \xi d\xi + \frac{W_2 L \omega^2}{g} \\ &= \frac{W_1 \omega^2}{2gL} (L^2 - x^2) + \frac{W_2 L \omega^2}{g} \end{aligned}$$

ELONGATION OF BAR  $BC$

$$\begin{aligned} \delta &= \int_0^L \frac{F(x) dx}{EA} \\ &= \int_0^L \frac{W_1 \omega^2}{2gLEA} (L^2 - x^2) dx + \int_0^L \frac{W_2 L \omega^2 dx}{gEA} \\ &= \frac{W_1 \omega^2}{2gLEA} \left[ \int_0^L L^2 dx - \int_0^L x^2 dx \right] + \frac{W_2 L \omega^2}{gEA} \int_0^L dx \\ &= \frac{W_1 L^2 \omega^2}{3gEA} + \frac{W_2 L^2 \omega^2}{gEA} \\ &= \frac{L^2 \omega^2}{3gEA} (W_1 + 3W_2) \quad \leftarrow \end{aligned}$$

**Problem 2.3-15** The main cables of a suspension bridge [see part (a) of the figure] follow a curve that is nearly parabolic because the primary load on the cables is the weight of the bridge deck, which is uniform in intensity along the horizontal. Therefore, let us represent the central region  $AOB$  of one of the main cables [see part (b) of the figure] as a parabolic cable supported at points  $A$  and  $B$  and carrying a uniform load of intensity  $q$  along the horizontal. The span of the cable is  $L$ , the sag is  $h$ , the axial rigidity is  $EA$ , and the origin of coordinates is at midspan.

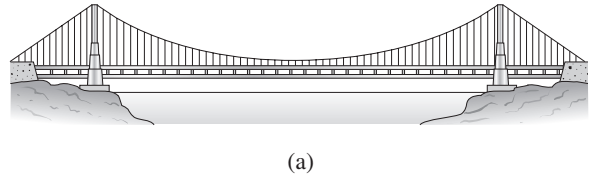

- (a) Derive the following formula for the elongation of cable  $AOB$  shown in part (b) of the figure:

$$\delta = \frac{qL^3}{8hEA} \left( 1 + \frac{16h^2}{3L^2} \right)$$

- (b) Calculate the elongation  $\delta$  of the central span of one of the main cables of the Golden Gate Bridge, for which the dimensions and properties are  $L = 4200$  ft,  $h = 470$  ft,  $q = 12,700$  lb/ft, and  $E = 28,800,000$  psi. The cable consists of 27,572 parallel wires of diameter 0.196 in.

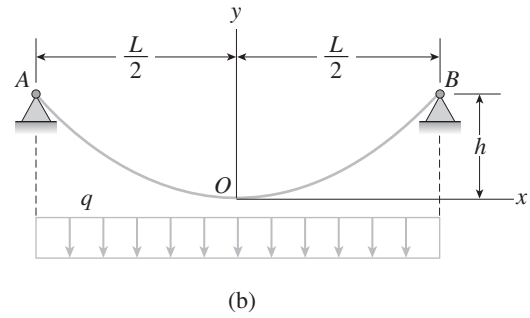

*Hint:* Determine the tensile force  $T$  at any point in the cable from a free-body diagram of part of the cable; then determine the elongation of an element of the cable of length  $ds$ ; finally, integrate along the curve of the cable to obtain an equation for the elongation  $\delta$ .

**Solution 2.3-15 Cable of a suspension bridge**

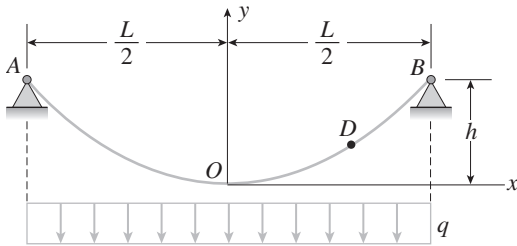

Equation of parabolic curve:

$$y = \frac{4hx^2}{L^2}$$

$$\frac{dy}{dx} = \frac{8hx}{L^2}$$

FREE-BODY DIAGRAM OF HALF OF CABLE

$$\Sigma M_B = 0 \quad \curvearrowright \curvearrowleft$$

$$-Hh + \frac{qL}{2} \left( \frac{L}{4} \right) = 0$$

$$H = \frac{qL^2}{8h}$$

$$\Sigma F_{\text{horizontal}} = 0$$

$$H_B = H = \frac{qL^2}{8h} \tag{Eq. 1}$$

$$\Sigma F_{\text{vertical}} = 0$$

$$V_B = \frac{qL}{2} \tag{Eq. 2}$$

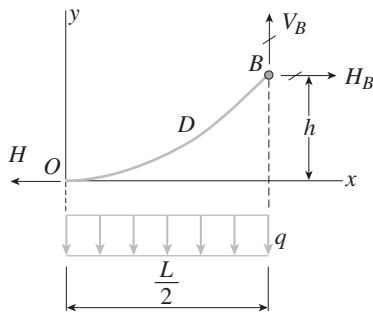

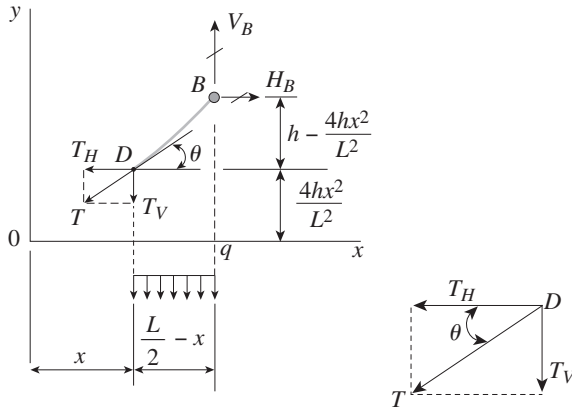
FREE-BODY DIAGRAM OF SEGMENT  $DB$  OF CABLE

$$\begin{aligned} \Sigma F_{\text{horiz}} = 0 \quad T_H &= H_B \\ &= \frac{qL^2}{8h} \end{aligned} \quad (\text{Eq. 3})$$

$$\Sigma F_{\text{vert}} = 0 \quad V_B - T_V - q\left(\frac{L}{2} - x\right) = 0$$

$$\begin{aligned} T_V &= V_B - q\left(\frac{L}{2} - x\right) = \frac{qL}{2} - \frac{qL}{2} + qx \\ &= qx \end{aligned} \quad (\text{Eq. 4})$$

TENSILE FORCE  $T$  IN CABLE

$$\begin{aligned} T &= \sqrt{T_H^2 + T_V^2} = \sqrt{\left(\frac{qL^2}{8h}\right)^2 + (qx)^2} \\ &= \frac{qL^2}{8h} \sqrt{1 + \frac{64h^2x^2}{L^4}} \end{aligned} \quad (\text{Eq. 5})$$

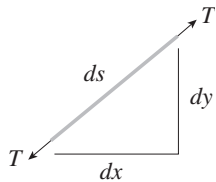
ELONGATION  $d\delta$  OF AN ELEMENT OF LENGTH  $ds$ 

$$d\delta = \frac{Tds}{EA}$$

$$\begin{aligned} ds &= \sqrt{(dx)^2 + (dy)^2} = dx \sqrt{1 + \left(\frac{dy}{dx}\right)^2} \\ &= dx \sqrt{1 + \left(\frac{8hx}{L^2}\right)^2} \\ &= dx \sqrt{1 + \frac{64h^2x^2}{L^4}} \end{aligned} \quad (\text{Eq. 6})$$

(a) ELONGATION  $\delta$  OF CABLE  $AOB$ 

$$\delta = \int d\delta = \int \frac{T ds}{EA}$$

Substitute for  $T$  from Eq. (5) and for  $ds$  from Eq. (6):

$$\delta = \frac{1}{EA} \int \frac{qL^2}{8h} \left(1 + \frac{64h^2x^2}{L^4}\right) dx$$

For both halves of cable:

$$\delta = \frac{2}{EA} \int_0^{L/2} \frac{qL^2}{8h} \left(1 + \frac{64h^2x^2}{L^4}\right) dx$$

$$\delta = \frac{qL^3}{8hEA} \left(1 + \frac{16h^2}{3L^2}\right) \quad \leftarrow \quad (\text{Eq. 7})$$

(b) GOLDEN GATE BRIDGE CABLE

$$\begin{aligned} L &= 4200 \text{ ft} & h &= 470 \text{ ft} \\ q &= 12,700 \text{ lb/ft} & E &= 28,800,000 \text{ psi} \end{aligned}$$

27,572 wires of diameter  $d = 0.196$  in.

$$A = (27,572) \left(\frac{\pi}{4}\right) (0.196 \text{ in.})^2 = 831.90 \text{ in.}^2$$

Substitute into Eq. (7):

$$\delta = 133.7 \text{ in} = 11.14 \text{ ft} \quad \leftarrow$$

### Statically Indeterminate Structures

**Problem 2.4-1** The assembly shown in the figure consists of a brass core (diameter  $d_1 = 0.25$  in.) surrounded by a steel shell (inner diameter  $d_2 = 0.28$  in., outer diameter  $d_3 = 0.35$  in.). A load  $P$  compresses the core and shell, which have length  $L = 4.0$  in. The moduli of elasticity of the brass and steel are  $E_b = 15 \times 10^6$  psi and  $E_s = 30 \times 10^6$  psi, respectively.

- What load  $P$  will compress the assembly by 0.003 in.?
- If the allowable stress in the steel is 22 ksi and the allowable stress in the brass is 16 ksi, what is the allowable compressive load  $P_{\text{allow}}$ ? (Suggestion: Use the equations derived in Example 2-5.)

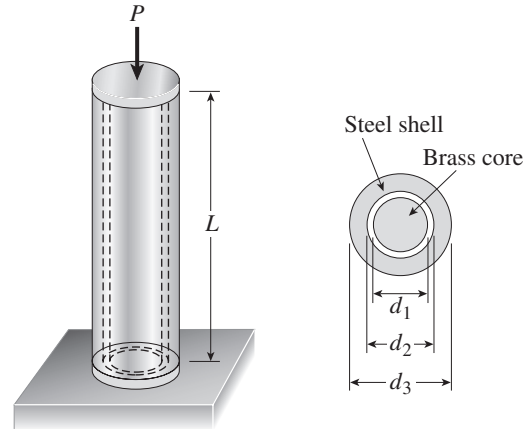

### Solution 2.4-1 Cylindrical assembly in compression

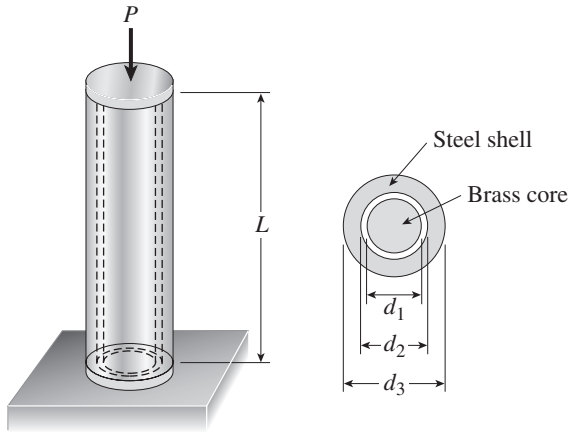

$$d_1 = 0.25 \text{ in.} \quad E_b = 15 \times 10^6 \text{ psi}$$

$$d_2 = 0.28 \text{ in.} \quad E_s = 30 \times 10^6 \text{ psi}$$

$$d_3 = 0.35 \text{ in.} \quad A_s = \frac{\pi}{4}(d_3^2 - d_2^2) = 0.03464 \text{ in.}^2$$

$$L = 4.0 \text{ in.} \quad A_b = \frac{\pi}{4}d_1^2 = 0.04909 \text{ in.}^2$$

(a) DECREASE IN LENGTH ( $\delta = 0.003$  in.)

Use Eq. (2-13) of Example 2-5.

$$\delta = \frac{PL}{E_s A_s + E_b A_b} \quad \text{or}$$

$$P = (E_s A_s + E_b A_b) \left( \frac{\delta}{L} \right)$$

Substitute numerical values:

$$\begin{aligned} E_s A_s + E_b A_b &= (30 \times 10^6 \text{ psi})(0.03464 \text{ in.}^2) \\ &\quad + (15 \times 10^6 \text{ psi})(0.04909 \text{ in.}^2) \\ &= 1.776 \times 10^6 \text{ lb} \end{aligned}$$

$$\begin{aligned} P &= (1.776 \times 10^6 \text{ lb}) \left( \frac{0.003 \text{ in.}}{4.0 \text{ in.}} \right) \\ &= 1330 \text{ lb} \quad \leftarrow \end{aligned}$$

(b) ALLOWABLE LOAD

$$\sigma_s = 22 \text{ ksi} \quad \sigma_b = 16 \text{ ksi}$$

Use Eqs. (2-12a and b) of Example 2-5.

For steel:

$$\sigma_s = \frac{PE_s}{E_s A_s + E_b A_b} \quad P_s = (E_s A_s + E_b A_b) \frac{\sigma_s}{E_s}$$

$$P_s = (1.776 \times 10^6 \text{ lb}) \left( \frac{22 \text{ ksi}}{30 \times 10^6 \text{ psi}} \right) = 1300 \text{ lb}$$

For brass:

$$\sigma_b = \frac{PE_b}{E_s A_s + E_b A_b} \quad P_b = (E_s A_s + E_b A_b) \frac{\sigma_b}{E_b}$$

$$P_b = (1.776 \times 10^6 \text{ lb}) \left( \frac{16 \text{ ksi}}{15 \times 10^6 \text{ psi}} \right) = 1890 \text{ lb}$$

Steel governs.  $P_{\text{allow}} = 1300 \text{ lb} \quad \leftarrow$

**Problem 2.4-2** A cylindrical assembly consisting of a brass core and an aluminum collar is compressed by a load  $P$  (see figure). The length of the aluminum collar and brass core is 350 mm, the diameter of the core is 25 mm, and the outside diameter of the collar is 40 mm. Also, the moduli of elasticity of the aluminum and brass are 72 GPa and 100 GPa, respectively.

- (a) If the length of the assembly decreases by 0.1% when the load  $P$  is applied, what is the magnitude of the load?
- (b) What is the maximum permissible load  $P_{\max}$  if the allowable stresses in the aluminum and brass are 80 MPa and 120 MPa, respectively? (*Suggestion:* Use the equations derived in Example 2-5.)

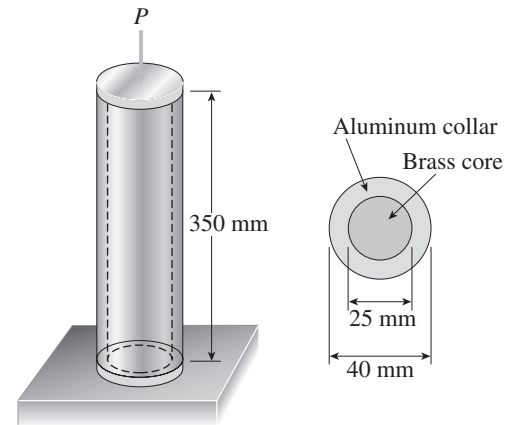

**Solution 2.4-2 Cylindrical assembly in compression**

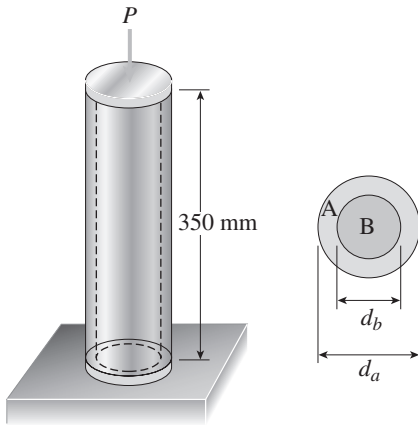

$A$  = aluminum

$B$  = brass

$L = 350$  mm

$d_a = 40$  mm

$d_b = 25$  mm

$$A_a = \frac{\pi}{4}(d_a^2 - d_b^2)$$

$$= 765.8 \text{ mm}^2$$

$$E_a = 72 \text{ GPa} \quad E_b = 100 \text{ GPa} \quad A_b = \frac{\pi}{4}d_b^2$$

$$= 490.9 \text{ mm}^2$$

(a) DECREASE IN LENGTH

$$(\delta = 0.1\% \text{ of } L = 0.350 \text{ mm})$$

Use Eq. (2-13) of Example 2-5.

$$\delta = \frac{PL}{E_a A_a + E_b A_b} \quad \text{or}$$

$$P = (E_a A_a + E_b A_b) \left( \frac{\delta}{L} \right)$$

Substitute numerical values:

$$\begin{aligned} E_a A_a + E_b A_b &= (72 \text{ GPa})(765.8 \text{ mm}^2) \\ &\quad + (100 \text{ GPa})(490.9 \text{ mm}^2) \\ &= 55.135 \text{ MN} + 49.090 \text{ MN} \\ &= 104.23 \text{ MN} \end{aligned}$$

$$P = (104.23 \text{ MN}) \left( \frac{0.350 \text{ mm}}{350 \text{ mm}} \right)$$

$$= 104.2 \text{ kN} \quad \leftarrow$$

(b) ALLOWABLE LOAD

$$\sigma_a = 80 \text{ MPa} \quad \sigma_b = 120 \text{ MPa}$$

Use Eqs. (2-12a and b) of Example 2-5.

For aluminum:

$$\sigma_a = \frac{PE_a}{E_a A_a + E_b A_b} \quad P_a = (E_a A_a + E_b A_b) \left( \frac{\sigma_a}{E_a} \right)$$

$$P_a = (104.23 \text{ MN}) \left( \frac{80 \text{ MPa}}{72 \text{ GPa}} \right) = 115.8 \text{ kN}$$

For brass:

$$\sigma_b = \frac{PE_b}{E_a A_a + E_b A_b} \quad P_b = (E_a A_a + E_b A_b) \left( \frac{\sigma_b}{E_b} \right)$$

$$P_b = (104.23 \text{ MN}) \left( \frac{120 \text{ MPa}}{100 \text{ GPa}} \right) = 125.1 \text{ kN}$$

$$\text{Aluminum governs.} \quad P_{\max} = 116 \text{ kN} \quad \leftarrow$$

**Problem 2.4-3** Three prismatic bars, two of material *A* and one of material *B*, transmit a tensile load *P* (see figure). The two outer bars (material *A*) are identical. The cross-sectional area of the middle bar (material *B*) is 50% larger than the cross-sectional area of one of the outer bars. Also, the modulus of elasticity of material *A* is twice that of material *B*.

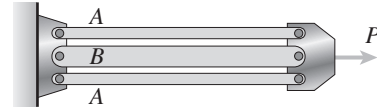

- (a) What fraction of the load *P* is transmitted by the middle bar?
- (b) What is the ratio of the stress in the middle bar to the stress in the outer bars?
- (c) What is the ratio of the strain in the middle bar to the strain in the outer bars?

**Solution 2.4-3 Prismatic bars in tension**

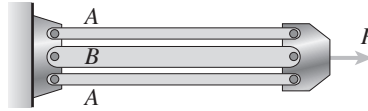

FREE-BODY DIAGRAM OF END PLATE

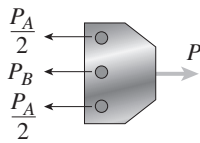

EQUATION OF EQUILIBRIUM

$$\Sigma F_{\text{horiz}} = 0 \quad P_A + P_B - P = 0 \quad (1)$$

EQUATION OF COMPATIBILITY

$$\delta_A = \delta_B \quad (2)$$

FORCE-DISPLACEMENT RELATIONS

$A_A$  = total area of both outer bars

$$\delta_A = \frac{P_A L}{E_A A_A} \quad \delta_B = \frac{P_B L}{E_B A_B} \quad (3)$$

Substitute into Eq. (2):

$$\frac{P_A L}{E_A A_A} = \frac{P_B L}{E_B A_B} \quad (4)$$

SOLUTION OF THE EQUATIONS

Solve simultaneously Eqs. (1) and (4):

$$P_A = \frac{E_A A_A P}{E_A A_A + E_B A_B} \quad P_B = \frac{E_B A_B P}{E_A A_A + E_B A_B} \quad (5)$$

Substitute into Eq. (3):

$$\delta = \delta_A = \delta_B = \frac{PL}{E_A A_A + E_B A_B} \quad (6)$$

STRESSES:

$$\sigma_A = \frac{P_A}{A_A} = \frac{E_A P}{E_A A_A + E_B A_B}$$

$$\sigma_B = \frac{P_B}{A_B} = \frac{E_B P}{E_A A_A + E_B A_B} \quad (7)$$

(a) LOAD IN MIDDLE BAR

$$\frac{P_B}{P} = \frac{E_B A_B}{E_A A_A + E_B A_B} = \frac{1}{\frac{E_A A_A}{E_B A_B} + 1}$$

Given:  $\frac{E_A}{E_B} = 2$      $\frac{A_A}{A_B} = \frac{1+1}{1.5} = \frac{4}{3}$

$$\therefore \frac{P_B}{P} = \frac{1}{\left(\frac{E_A}{E_B}\right)\left(\frac{A_A}{A_B}\right) + 1} = \frac{1}{\frac{8}{3} + 1} = \frac{3}{11} \quad \leftarrow$$

(b) RATIO OF STRESSES

$$\frac{\sigma_B}{\sigma_A} = \frac{E_B}{E_A} = \frac{1}{2} \quad \leftarrow$$

(c) RATIO OF STRAINS

All bars have the same strain

Ratio = 1     $\leftarrow$

**Problem 2.4-4** A bar  $ACB$  having two different cross-sectional areas  $A_1$  and  $A_2$  is held between rigid supports at  $A$  and  $B$  (see figure). A load  $P$  acts at point  $C$ , which is distance  $b_1$  from end  $A$  and distance  $b_2$  from end  $B$ .

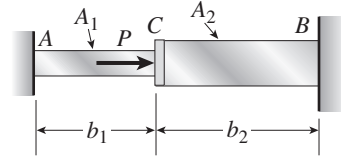

- Obtain formulas for the reactions  $R_A$  and  $R_B$  at supports  $A$  and  $B$ , respectively, due to the load  $P$ .
- Obtain a formula for the displacement  $\delta_C$  of point  $C$ .
- What is the ratio of the stress  $\sigma_1$  in region  $AC$  to the stress  $\sigma_2$  in region  $CB$ ?

**Solution 2.4-4 Bar with intermediate load**

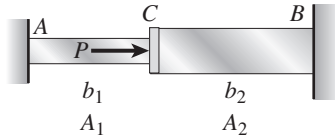

FREE-BODY DIAGRAM

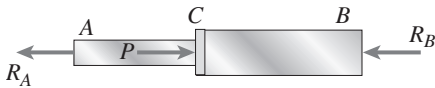

EQUATION OF EQUILIBRIUM

$$\Sigma F_{\text{horiz}} = 0 \quad R_A + R_B = P \quad (\text{Eq. 1})$$

EQUATION OF COMPATIBILITY

$\delta_{AC}$  = elongation of  $AC$

$\delta_{CB}$  = shortening of  $CB$

$$\delta_{AC} = \delta_{CB} \quad (\text{Eq. 2})$$

FORCE DISPLACEMENT RELATIONS

$$\delta_{AC} = \frac{R_A b_1}{EA_1} \quad \delta_{CB} = \frac{R_B b_2}{EA_2} \quad (\text{Eqs. 3\&4})$$

(a) SOLUTION OF EQUATIONS

Substitute Eq. (3) and Eq. (4) into Eq. (2):

$$\frac{R_A b_1}{EA_1} = \frac{R_B b_2}{EA_2} \quad (\text{Eq. 5})$$

Solve Eq. (1) and Eq. (5) simultaneously:

$$R_A = \frac{b_2 A_1 P}{b_1 A_2 + b_2 A_1} \quad R_B = \frac{b_1 A_2 P}{b_1 A_2 + b_2 A_1} \quad \leftarrow$$

(b) DISPLACEMENT OF POINT  $C$

$$\delta_C = \delta_{AC} = \frac{R_A b_1}{EA_1} = \frac{b_1 b_2 P}{E(b_1 A_2 + b_2 A_1)} \quad \leftarrow$$

(c) RATIO OF STRESSES

$$\sigma_1 = \frac{R_A}{A_1} \text{ (tension)} \quad \sigma_2 = \frac{R_B}{A_2} \text{ (compression)}$$

$$\frac{\sigma_1}{\sigma_2} = \frac{b_2}{b_1} \quad \leftarrow$$

(Note that if  $b_1 = b_2$ , the stresses are numerically equal regardless of the areas  $A_1$  and  $A_2$ .)

**Problem 2.4-5** Three steel cables jointly support a load of 12 k (see figure). The diameter of the middle cable is  $\frac{3}{4}$  in. and the diameter of each outer cable is  $\frac{1}{2}$  in. The tensions in the cables are adjusted so that each cable carries one-third of the load (i.e., 4 k). Later, the load is increased by 9 k to a total load of 21 k.

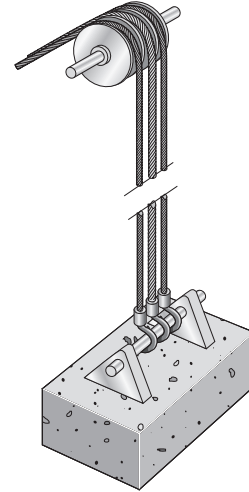

- (a) What percent of the total load is now carried by the middle cable?
- (b) What are the stresses  $\sigma_M$  and  $\sigma_O$  in the middle and outer cables, respectively? (Note: See Table 2-1 in Section 2.2 for properties of cables.)

**Solution 2.4-5 Three cables in tension**

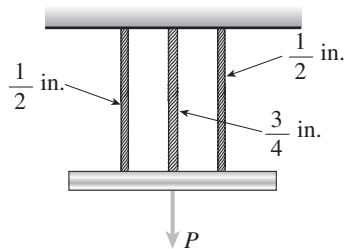

AREAS OF CABLES (from Table 2-1)

Middle cable:  $A_M = 0.268 \text{ in.}^2$

Outer cables:  $A_O = 0.119 \text{ in.}^2$

(for each cable)

FIRST LOADING

$$P_1 = 12 \text{ k (Each cable carries } \frac{P_1}{3} \text{ or 4 k.)}$$

SECOND LOADING

$P_2 = 9 \text{ k (additional load)}$

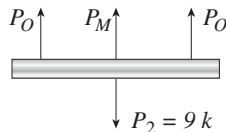

EQUATION OF EQUILIBRIUM

$$\Sigma F_{\text{vert}} = 0 \quad 2P_O + P_M - P_2 = 0 \quad (1)$$

EQUATION OF COMPATIBILITY

$$\delta_M = \delta_O \quad (2)$$

FORCE-DISPLACEMENT RELATIONS

$$\delta_M = \frac{P_M L}{EA_M} \quad \delta_O = \frac{P_O L}{EA_O} \quad (3, 4)$$

SUBSTITUTE INTO COMPATIBILITY EQUATION:

$$\frac{P_M L}{EA_M} = \frac{P_O L}{EA_O} \quad \frac{P_M}{A_M} = \frac{P_O}{A_O} \quad (5)$$

SOLVE SIMULTANEOUSLY EQS. (1) AND (5):

$$P_M = P_2 \left( \frac{A_M}{A_M + 2A_O} \right) = (9 \text{ k}) \left( \frac{0.268 \text{ in.}^2}{0.506 \text{ in.}^2} \right) = 4.767 \text{ k}$$

$$P_O = P_2 \left( \frac{A_O}{A_M + 2A_O} \right) = (9 \text{ k}) \left( \frac{0.119 \text{ in.}^2}{0.506 \text{ in.}^2} \right) = 2.117 \text{ k}$$

FORCES IN CABLES

Middle cable: Force = 4 k + 4.767 k = 8.767 k

Outer cables: Force = 4 k + 2.117 k = 6.117 k

(for each cable)

(a) PERCENT OF TOTAL LOAD CARRIED BY MIDDLE CABLE

$$\text{Percent} = \frac{8.767 \text{ k}}{21 \text{ k}} (100\%) = 41.7\% \quad \leftarrow$$

(b) STRESSES IN CABLES ( $\sigma = P/A$ )

$$\text{Middle cable: } \sigma_M = \frac{8.767 \text{ k}}{0.268 \text{ in.}^2} = 32.7 \text{ ksi} \quad \leftarrow$$

$$\text{Outer cables: } \sigma_O = \frac{6.117 \text{ k}}{0.119 \text{ in.}^2} = 51.4 \text{ ksi} \quad \leftarrow$$

**Problem 2.4-6** A plastic rod  $AB$  of length  $L = 0.5$  m has a diameter  $d_1 = 30$  mm (see figure). A plastic sleeve  $CD$  of length  $c = 0.3$  m and outer diameter  $d_2 = 45$  mm is securely bonded to the rod so that no slippage can occur between the rod and the sleeve. The rod is made of an acrylic with modulus of elasticity  $E_1 = 3.1$  GPa and the sleeve is made of a polyamide with  $E_2 = 2.5$  GPa.

- Calculate the elongation  $\delta$  of the rod when it is pulled by axial forces  $P = 12$  kN.
- If the sleeve is extended for the full length of the rod, what is the elongation?
- If the sleeve is removed, what is the elongation?

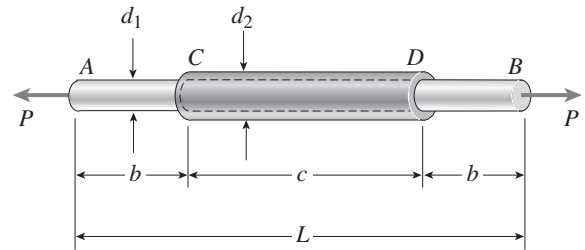

**Solution 2.4-6 Plastic rod with sleeve**

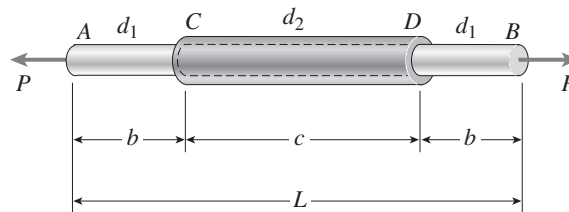

$$P = 12 \text{ kN} \quad d_1 = 30 \text{ mm} \quad b = 100 \text{ mm}$$

$$L = 500 \text{ mm} \quad d_2 = 45 \text{ mm} \quad c = 300 \text{ mm}$$

$$\text{Rod: } E_1 = 3.1 \text{ GPa}$$

$$\text{Sleeve: } E_2 = 2.5 \text{ GPa}$$

$$\text{Rod: } A_1 = \frac{\pi d_1^2}{4} = 706.86 \text{ mm}^2$$

$$\text{Sleeve: } A_2 = \frac{\pi}{4}(d_2^2 - d_1^2) = 883.57 \text{ mm}^2$$

$$E_1 A_1 + E_2 A_2 = 4.400 \text{ MN}$$

(a) ELONGATION OF ROD

$$\text{Part AC: } \delta_{AC} = \frac{Pb}{E_1 A_1} = 0.5476 \text{ mm}$$

$$\begin{aligned} \text{Part CD: } \delta_{CD} &= \frac{Pc}{E_1 A_1 E_2 A_2} \\ &= 0.81815 \text{ mm} \end{aligned}$$

(From Eq. 2-13 of Example 2-5)

$$\delta = 2\delta_{AC} + \delta_{CD} = 1.91 \text{ mm} \quad \leftarrow$$

(b) SLEEVE AT FULL LENGTH

$$\begin{aligned} \delta &= \delta_{CD} \left( \frac{L}{c} \right) = (0.81815 \text{ mm}) \left( \frac{500 \text{ mm}}{300 \text{ mm}} \right) \\ &= 1.36 \text{ mm} \quad \leftarrow \end{aligned}$$

(c) SLEEVE REMOVED

$$\delta = \frac{PL}{E_1 A_1} = 2.74 \text{ mm} \quad \leftarrow$$

**Problem 2.4-7** The axially loaded bar  $ABCD$  shown in the figure is held between rigid supports. The bar has cross-sectional area  $A_1$  from  $A$  to  $C$  and  $2A_1$  from  $C$  to  $D$ .

- (a) Derive formulas for the reactions  $R_A$  and  $R_D$  at the ends of the bar.
- (b) Determine the displacements  $\delta_B$  and  $\delta_C$  at points  $B$  and  $C$ , respectively.
- (c) Draw a diagram in which the abscissa is the distance from the left-hand support to any point in the bar and the ordinate is the horizontal displacement  $\delta$  at that point.

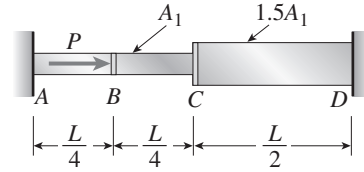

**Solution 2.4-7 Bar with fixed ends**

FREE-BODY DIAGRAM OF BAR

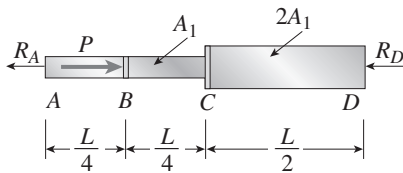

EQUATION OF EQUILIBRIUM

$$\Sigma F_{\text{horiz}} = 0 \qquad R_A + R_D = P \qquad \text{(Eq. 1)}$$

EQUATION OF COMPATIBILITY

$$\delta_{AB} + \delta_{BC} + \delta_{CD} = 0 \qquad \text{(Eq. 2)}$$

Positive means elongation.

FORCE-DISPLACEMENT EQUATIONS

$$\delta_{AB} = \frac{R_A(L/4)}{EA_1} \qquad \delta_{BC} = \frac{(R_A - P)(L/4)}{EA_1} \qquad \text{(Eqs. 3, 4)}$$

$$\delta_{CD} = -\frac{R_D(L/2)}{E(2A_1)} \qquad \text{(Eq. 5)}$$

SOLUTION OF EQUATIONS

Substitute Eqs. (3), (4), and (5) into Eq. (2):

$$\frac{R_A L}{4EA_1} + \frac{(R_A - P)(L)}{4EA_1} - \frac{R_D L}{4EA_1} = 0 \qquad \text{(Eq. 6)}$$

(a) REACTIONS

Solve simultaneously Eqs. (1) and (6):

$$R_A = \frac{2P}{3} \qquad R_D = \frac{P}{3} \quad \leftarrow$$

(b) DISPLACEMENTS AT POINTS  $B$  AND  $C$

$$\delta_B = \delta_{AB} = \frac{R_A L}{4EA_1} = \frac{PL}{6EA_1} \quad \text{(To the right)} \quad \leftarrow$$

$$\delta_C = |\delta_{CD}| = \frac{R_D L}{4EA_1} = \frac{PL}{12EA_1} \quad \text{(To the right)} \quad \leftarrow$$

(c) DISPLACEMENT DIAGRAM

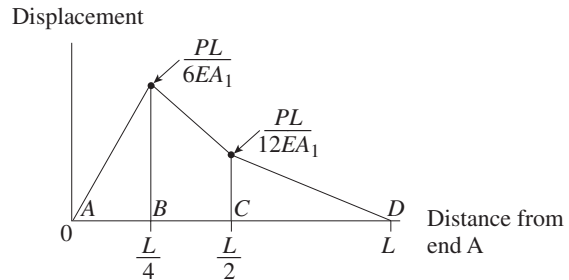

**Problem 2.4-8** The fixed-end bar  $ABCD$  consists of three prismatic segments, as shown in the figure. The end segments have cross-sectional area  $A_1 = 840 \text{ mm}^2$  and length  $L_1 = 200 \text{ mm}$ . The middle segment has cross-sectional area  $A_2 = 1260 \text{ mm}^2$  and length  $L_2 = 250 \text{ mm}$ . Loads  $P_B$  and  $P_C$  are equal to  $25.5 \text{ kN}$  and  $17.0 \text{ kN}$ , respectively.

- (a) Determine the reactions  $R_A$  and  $R_D$  at the fixed supports.  
 (b) Determine the compressive axial force  $F_{BC}$  in the middle segment of the bar.

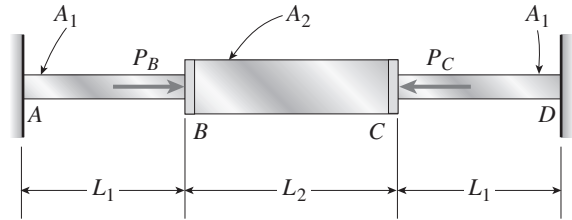

**Solution 2.4-8 Bar with three segments**

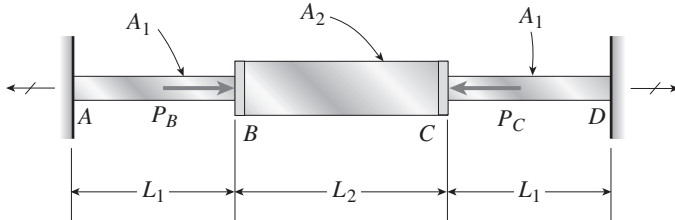

$$\begin{aligned} P_B &= 25.5 \text{ kN} & P_C &= 17.0 \text{ kN} \\ L_1 &= 200 \text{ mm} & L_2 &= 250 \text{ mm} \\ A_1 &= 840 \text{ mm}^2 & A_2 &= 1260 \text{ mm}^2 \\ m &= \text{meter} \end{aligned}$$

**FREE-BODY DIAGRAM**



**EQUATION OF EQUILIBRIUM**

$$\Sigma F_{\text{horiz}} = 0 \quad \rightarrow \quad \leftarrow$$

$$P_B + R_D - P_C - R_A = 0 \quad \text{or}$$

$$R_A - R_D = P_B - P_C = 8.5 \text{ kN} \quad (\text{Eq. 1})$$

**EQUATION OF COMPATIBILITY**

$$\delta_{AD} = \text{elongation of entire bar}$$

$$\delta_{AD} = \delta_{AB} + \delta_{BC} + \delta_{CD} = 0 \quad (\text{Eq. 2})$$

**FORCE-DISPLACEMENT RELATIONS**

$$\delta_{AB} = \frac{R_A L_1}{EA_1} = \frac{R_A}{E} \left( 238.095 \frac{1}{\text{m}} \right) \quad (\text{Eq. 3})$$

$$\begin{aligned} \delta_{BC} &= \frac{(R_A - P_B)L_2}{EA_2} \\ &= \frac{R_A}{E} \left( 198.413 \frac{1}{\text{m}} \right) - \frac{P_B}{E} \left( 198.413 \frac{1}{\text{m}} \right) \end{aligned} \quad (\text{Eq. 4})$$

$$\delta_{CD} = \frac{R_D L_1}{EA_1} = \frac{R_D}{E} \left( 238.095 \frac{1}{\text{m}} \right) \quad (\text{Eq. 5})$$

**SOLUTION OF EQUATIONS**

Substitute Eqs. (3), (4), and (5) into Eq. (2):

$$\begin{aligned} \frac{R_A}{E} \left( 238.095 \frac{1}{\text{m}} \right) + \frac{R_A}{E} \left( 198.413 \frac{1}{\text{m}} \right) \\ - \frac{P_B}{E} \left( 198.413 \frac{1}{\text{m}} \right) + \frac{R_D}{E} \left( 238.095 \frac{1}{\text{m}} \right) = 0 \end{aligned}$$

Simplify and substitute  $P_B = 25.5 \text{ kN}$ :

$$\begin{aligned} R_A \left( 436.508 \frac{1}{\text{m}} \right) + R_D \left( 238.095 \frac{1}{\text{m}} \right) \\ = 5,059.53 \frac{\text{kN}}{\text{m}} \end{aligned} \quad (\text{Eq. 6})$$

(a) REACTIONS  $R_A$  AND  $R_D$

Solve simultaneously Eqs. (1) and (6).

$$\text{From (1): } R_D = R_A - 8.5 \text{ kN}$$

Substitute into (6) and solve for  $R_A$ :

$$R_A \left( 674.603 \frac{1}{\text{m}} \right) = 7083.34 \frac{\text{kN}}{\text{m}}$$

$$R_A = 10.5 \text{ kN} \quad \leftarrow$$

$$R_D = R_A - 8.5 \text{ kN} = 2.0 \text{ kN} \quad \leftarrow$$

(b) COMPRESSIVE AXIAL FORCE  $F_{BC}$

$$F_{BC} = P_B - R_A = P_C - R_D = 15.0 \text{ kN} \quad \leftarrow$$

**Problem 2.4-9** The aluminum and steel pipes shown in the figure are fastened to rigid supports at ends *A* and *B* and to a rigid plate *C* at their junction. The aluminum pipe is twice as long as the steel pipe. Two equal and symmetrically placed loads *P* act on the plate at *C*.

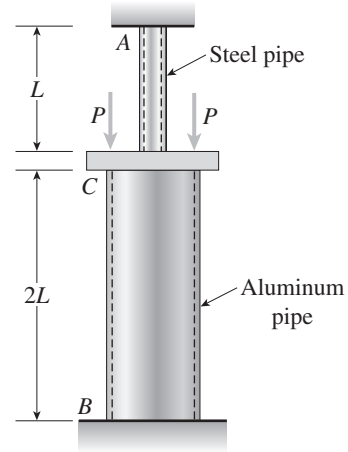

- (a) Obtain formulas for the axial stresses  $\sigma_a$  and  $\sigma_s$  in the aluminum and steel pipes, respectively.
- (b) Calculate the stresses for the following data:  $P = 12$  k, cross-sectional area of aluminum pipe  $A_a = 8.92$  in.<sup>2</sup>, cross-sectional area of steel pipe  $A_s = 1.03$  in.<sup>2</sup>, modulus of elasticity of aluminum  $E_a = 10 \times 10^6$  psi, and modulus of elasticity of steel  $E_s = 29 \times 10^6$  psi.

**Solution 2.4-9 Pipes with intermediate loads**

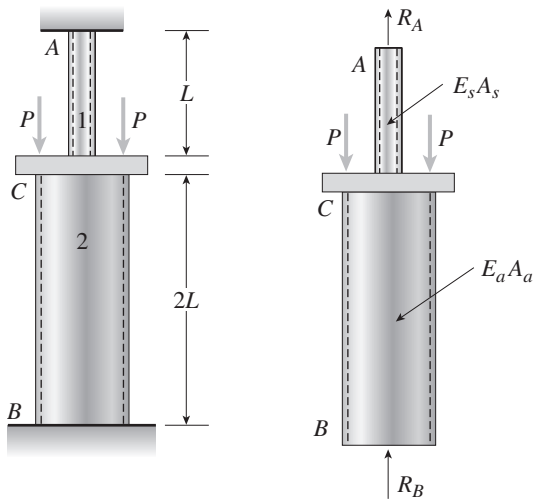

Pipe 1 is steel.  
Pipe 2 is aluminum.

**EQUATION OF EQUILIBRIUM**

$$\Sigma F_{\text{vert}} = 0 \quad R_A + R_B = 2P \quad (\text{Eq. 1})$$

**EQUATION OF COMPATIBILITY**

$$\delta_{AB} = \delta_{AC} + \delta_{CB} = 0 \quad (\text{Eq. 2})$$

(A positive value of  $\delta$  means elongation.)

**FORCE-DISPLACEMENT RELATIONS**

$$\delta_{AC} = \frac{R_A L}{E_s A_s} \quad \delta_{BC} = -\frac{R_B (2L)}{E_a A_a} \quad (\text{Eqs. 3, 4})$$

**SOLUTION OF EQUATIONS**

Substitute Eqs. (3) and (4) into Eq. (2):

$$\frac{R_A L}{E_s A_s} - \frac{R_B (2L)}{E_a A_a} = 0 \quad (\text{Eq. 5})$$

Solve simultaneously Eqs. (1) and (5):

$$R_A = \frac{4E_s A_s P}{E_a A_a + 2E_s A_s} \quad R_B = \frac{2E_a A_a P}{E_a A_a + 2E_s A_s} \quad (\text{Eqs. 6, 7})$$

**(a) AXIAL STRESSES**

$$\text{Aluminum: } \sigma_a = \frac{R_B}{A_a} = \frac{2E_a P}{E_a A_a + 2E_s A_s} \quad \leftarrow \quad (\text{Eq. 8})$$

(compression)

$$\text{Steel: } \sigma_s = \frac{R_A}{A_s} = \frac{4E_s P}{E_a A_a + 2E_s A_s} \quad \leftarrow \quad (\text{Eq. 9})$$

(tension)

**(b) NUMERICAL RESULTS**

$$P = 12 \text{ k} \quad A_a = 8.92 \text{ in.}^2 \quad A_s = 1.03 \text{ in.}^2$$

$$E_a = 10 \times 10^6 \text{ psi} \quad E_s = 29 \times 10^6 \text{ psi}$$

Substitute into Eqs. (8) and (9):

$$\sigma_a = 1,610 \text{ psi (compression)} \quad \leftarrow$$

$$\sigma_s = 9,350 \text{ psi (tension)} \quad \leftarrow$$

**Problem 2.4-10** A rigid bar of weight  $W = 800$  N hangs from three equally spaced vertical wires, two of steel and one of aluminum (see figure). The wires also support a load  $P$  acting at the midpoint of the bar. The diameter of the steel wires is 2 mm, and the diameter of the aluminum wire is 4 mm.

What load  $P_{\text{allow}}$  can be supported if the allowable stress in the steel wires is 220 MPa and in the aluminum wire is 80 MPa? (Assume  $E_s = 210$  GPa and  $E_a = 70$  GPa.)

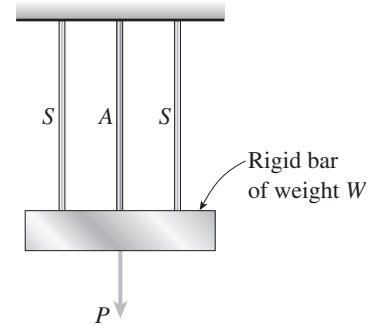

### Solution 2.4-10 Rigid bar hanging from three wires

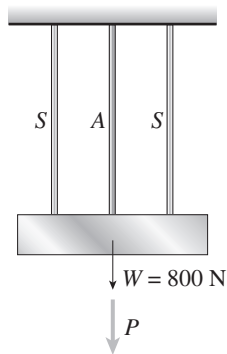

STEEL WIRES

$$d_s = 2 \text{ mm} \quad \sigma_s = 220 \text{ MPa} \quad E_s = 210 \text{ GPa}$$

ALUMINUM WIRES

$$d_A = 4 \text{ mm} \quad \sigma_A = 80 \text{ MPa}$$

$$E_A = 70 \text{ GPa}$$

FREE-BODY DIAGRAM OF RIGID BAR

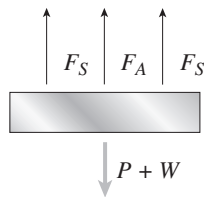

EQUATION OF EQUILIBRIUM

$$\Sigma F_{\text{vert}} = 0$$

$$2F_s + F_A - P - W = 0 \quad (\text{Eq. 1})$$

EQUATION OF COMPATIBILITY

$$\delta_s = \delta_A \quad (\text{Eq. 2})$$

FORCE-DISPLACEMENT RELATIONS

$$\delta_s = \frac{F_s L}{E_s A_s} \quad \delta_A = \frac{F_A L}{E_A A_A} \quad (\text{Eqs. 3, 4})$$

SOLUTION OF EQUATIONS

Substitute (3) and (4) into Eq. (2):

$$\frac{F_s L}{E_s A_s} = \frac{F_A L}{E_A A_A} \quad (\text{Eq. 5})$$

Solve simultaneously Eqs. (1) and (5):

$$F_A = (P + W) \left( \frac{E_A A_A}{E_A A_A + 2E_s A_s} \right) \quad (\text{Eq. 6})$$

$$F_s = (P + W) \left( \frac{E_s A_s}{E_A A_A + 2E_s A_s} \right) \quad (\text{Eq. 7})$$

STRESSES IN THE WIRES

$$\sigma_A = \frac{F_A}{A_A} = \frac{(P + W) E_A}{E_A A_A + 2E_s A_s} \quad (\text{Eq. 8})$$

$$\sigma_s = \frac{F_s}{A_s} = \frac{(P + W) E_s}{E_A A_A + 2E_s A_s} \quad (\text{Eq. 9})$$

ALLOWABLE LOADS (FROM EQS. (8) AND (9))

$$P_A = \frac{\sigma_A}{E_A} (E_A A_A + 2E_s A_s) - W \quad (\text{Eq. 10})$$

$$P_s = \frac{\sigma_s}{E_s} (E_A A_A + 2E_s A_s) - W \quad (\text{Eq. 11})$$

SUBSTITUTE NUMERICAL VALUES INTO EQS. (10) AND (11):

$$A_s = \frac{\pi}{4} (2 \text{ mm})^2 = 3.1416 \text{ mm}^2$$

$$A_A = \frac{\pi}{4} (4 \text{ mm})^2 = 12.5664 \text{ mm}^2$$

$$P_A = 1713 \text{ N}$$

$$P_s = 1504 \text{ N}$$

Steel governs.  $P_{\text{allow}} = 1500 \text{ N}$  ←

**Problem 2.4-11** A bimetallic bar (or composite bar) of square cross section with dimensions  $2b \times 2b$  is constructed of two different metals having moduli of elasticity  $E_1$  and  $E_2$  (see figure). The two parts of the bar have the same cross-sectional dimensions. The bar is compressed by forces  $P$  acting through rigid end plates. The line of action of the loads has an eccentricity  $e$  of such magnitude that each part of the bar is stressed uniformly in compression.

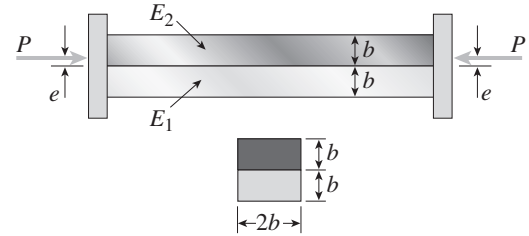

- (a) Determine the axial forces  $P_1$  and  $P_2$  in the two parts of the bar.
- (b) Determine the eccentricity  $e$  of the loads.
- (c) Determine the ratio  $\sigma_1/\sigma_2$  of the stresses in the two parts of the bar.

**Solution 2.4-11 Bimetallic bar in compression**

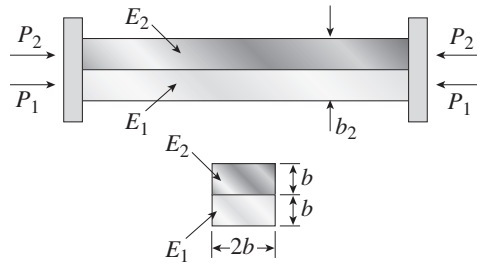

FREE-BODY DIAGRAM  
(Plate at right-hand end)

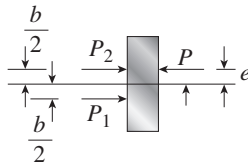

EQUATIONS OF EQUILIBRIUM

$$\Sigma F = 0 \quad P_1 + P_2 = P \quad (\text{Eq. 1})$$

$$\Sigma M = 0 \quad \curvearrowright \quad Pe + P_1\left(\frac{b}{2}\right) - P_2\left(\frac{b}{2}\right) = 0 \quad (\text{Eq. 2})$$

EQUATION OF COMPATIBILITY

$$\delta_2 = \delta_1$$

$$\frac{P_2 L}{E_2 A} = \frac{P_1 L}{E_1 A} \quad \text{or} \quad \frac{P_2}{E_2} = \frac{P_1}{E_1} \quad (\text{Eq. 3})$$

(a) AXIAL FORCES

Solve simultaneously Eqs. (1) and (3):

$$P_1 = \frac{PE_1}{E_1 + E_2} \quad P_2 = \frac{PE_2}{E_1 + E_2} \quad \leftarrow$$

(b) ECCENTRICITY OF LOAD  $P$

Substitute  $P_1$  and  $P_2$  into Eq. (2) and solve for  $e$ :

$$e = \frac{b(E_2 - E_1)}{2(E_2 + E_1)} \quad \leftarrow$$

(c) RATIO OF STRESSES

$$\sigma_1 = \frac{P_1}{A} \quad \sigma_2 = \frac{P_2}{A} \quad \frac{\sigma_1}{\sigma_2} = \frac{P_1}{P_2} = \frac{E_1}{E_2} \quad \leftarrow$$

**Problem 2.4-12** A circular steel bar  $ABC$  ( $E = 200$  GPa) has cross-sectional area  $A_1$  from  $A$  to  $B$  and cross-sectional area  $A_2$  from  $B$  to  $C$  (see figure). The bar is supported rigidly at end  $A$  and is subjected to a load  $P$  equal to  $40$  kN at end  $C$ . A circular steel collar  $BD$  having cross-sectional area  $A_3$  supports the bar at  $B$ . The collar fits snugly at  $B$  and  $D$  when there is no load.

Determine the elongation  $\delta_{AC}$  of the bar due to the load  $P$ . (Assume  $L_1 = 2L_3 = 250$  mm,  $L_2 = 225$  mm,  $A_1 = 2A_3 = 960$  mm<sup>2</sup>, and  $A_2 = 300$  mm<sup>2</sup>.)

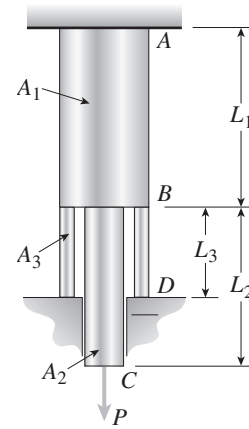

### Solution 2.4-12 Bar supported by a collar

FREE-BODY DIAGRAM OF BAR  $ABC$  AND COLLAR  $BD$

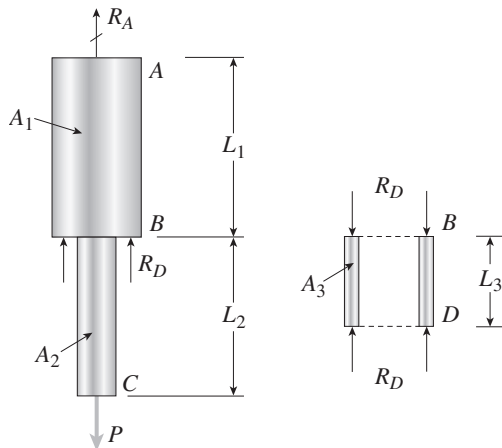

EQUILIBRIUM OF BAR  $ABC$

$$\sum F_{\text{vert}} = 0 \quad R_A + R_D - P = 0 \quad (\text{Eq. 1})$$

COMPATIBILITY (distance  $AD$  does not change)

$$\delta_{AB}(\text{bar}) + \delta_{BD}(\text{collar}) = 0 \quad (\text{Eq. 2})$$

(Elongation is positive.)

FORCE-DISPLACEMENT RELATIONS

$$\delta_{AB} = \frac{R_A L_1}{EA_1} \quad \delta_{BD} = -\frac{R_D L_3}{EA_3}$$

Substitute into Eq. (2):

$$\frac{R_A L_1}{EA_1} - \frac{R_D L_3}{EA_3} = 0 \quad (\text{Eq. 3})$$

SOLVE SIMULTANEOUSLY EQS. (1) AND (3):

$$R_A = \frac{PL_3 A_1}{L_1 A_3 + L_3 A_1} \quad R_D = \frac{PL_1 A_3}{L_1 A_3 + L_3 A_1}$$

CHANGES IN LENGTHS (Elongation is positive)

$$\delta_{AB} = \frac{R_A L_1}{EA_1} = \frac{PL_1 L_3}{E(L_1 A_3 + L_3 A_1)} \quad \delta_{BC} = \frac{PL_2}{EA_2}$$

ELONGATION OF BAR  $ABC$

$$\delta_{AC} = \delta_{AB} + \delta_{BC}$$

SUBSTITUTE NUMERICAL VALUES:

$$P = 40 \text{ kN} \quad E = 200 \text{ GPa}$$

$$L_1 = 250 \text{ mm}$$

$$L_2 = 225 \text{ mm}$$

$$L_3 = 125 \text{ mm}$$

$$A_1 = 960 \text{ mm}^2$$

$$A_2 = 300 \text{ mm}^2$$

$$A_3 = 480 \text{ mm}^2$$

RESULTS:

$$R_A = R_D = 20 \text{ kN}$$

$$\delta_{AB} = 0.02604 \text{ mm}$$

$$\delta_{BC} = 0.15000 \text{ mm}$$

$$\delta_{AC} = \delta_{AB} + \delta_{BC} = 0.176 \text{ mm} \quad \leftarrow$$

**Problem 2.4-13** A horizontal rigid bar of weight  $W = 7200$  lb is supported by three slender circular rods that are equally spaced (see figure). The two outer rods are made of aluminum ( $E_1 = 10 \times 10^6$  psi) with diameter  $d_1 = 0.4$  in. and length  $L_1 = 40$  in. The inner rod is magnesium ( $E_2 = 6.5 \times 10^6$  psi) with diameter  $d_2$  and length  $L_2$ . The allowable stresses in the aluminum and magnesium are 24,000 psi and 13,000 psi, respectively.

If it is desired to have all three rods loaded to their maximum allowable values, what should be the diameter  $d_2$  and length  $L_2$  of the middle rod?

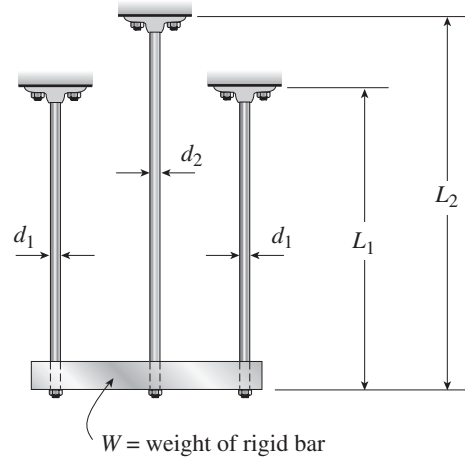

### Solution 2.4-13 Bar supported by three rods

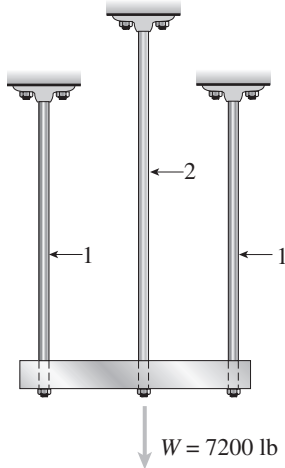

FREE-BODY DIAGRAM OF RIGID BAR  
EQUATION OF EQUILIBRIUM

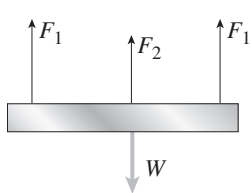

$$\begin{aligned} \Sigma F_{\text{vert}} &= 0 \\ 2F_1 + F_2 - W &= 0 \quad (\text{Eq. 1}) \end{aligned}$$

FULLY STRESSED RODS

$$\begin{aligned} F_1 &= \sigma_1 A_1 & F_2 &= \sigma_2 A_2 \\ A_1 &= \frac{\pi d_1^2}{4} & A_2 &= \frac{\pi d_2^2}{4} \end{aligned}$$

Substitute into Eq. (1):

$$2\sigma_1 \left( \frac{\pi d_1^2}{4} \right) + \sigma_2 \left( \frac{\pi d_2^2}{4} \right) = W$$

Diameter  $d_1$  is known; solve for  $d_2$ :

$$d_2^2 = \frac{4W}{\pi\sigma_2} - \frac{2\sigma_1 d_1^2}{\sigma_2} \quad \leftarrow \quad (\text{Eq. 2})$$

SUBSTITUTE NUMERICAL VALUES:

$$\begin{aligned} d_2^2 &= \frac{4(7200 \text{ lb})}{\pi(13,000 \text{ psi})} - \frac{2(24,000 \text{ psi})(0.4 \text{ in.})^2}{13,000 \text{ psi}} \\ &= 0.70518 \text{ in.}^2 - 0.59077 \text{ in.}^2 = 0.11441 \text{ in.}^2 \\ d_2 &= 0.338 \text{ in.} \quad \leftarrow \end{aligned}$$

EQUATION OF COMPATIBILITY

$$\delta_1 = \delta_2 \quad (\text{Eq. 3})$$

FORCE-DISPLACEMENT RELATIONS

$$\delta_1 = \frac{F_1 L_1}{E_1 A_1} = \sigma_1 \left( \frac{L_1}{E_1} \right) \quad (\text{Eq. 4})$$

$$\delta_2 = \frac{F_2 L_2}{E_2 A_2} = \sigma_2 \left( \frac{L_2}{E_2} \right) \quad (\text{Eq. 5})$$

Substitute (4) and (5) into Eq. (3):

$$\sigma_1 \left( \frac{L_1}{E_1} \right) = \sigma_2 \left( \frac{L_2}{E_2} \right)$$

Length  $L_1$  is known; solve for  $L_2$ :

$$L_2 = L_1 \left( \frac{\sigma_1 E_2}{\sigma_2 E_1} \right) \quad \leftarrow \quad (\text{Eq. 6})$$

SUBSTITUTE NUMERICAL VALUES:

$$\begin{aligned} L_2 &= (40 \text{ in.}) \left( \frac{24,000 \text{ psi}}{13,000 \text{ psi}} \right) \left( \frac{6.5 \times 10^6 \text{ psi}}{10 \times 10^6 \text{ psi}} \right) \\ &= 48.0 \text{ in.} \quad \leftarrow \end{aligned}$$

**Problem 2.4-14** A rigid bar  $ABCD$  is pinned at point  $B$  and supported by springs at  $A$  and  $D$  (see figure). The springs at  $A$  and  $D$  have stiffnesses  $k_1 = 10 \text{ kN/m}$  and  $k_2 = 25 \text{ kN/m}$ , respectively, and the dimensions  $a$ ,  $b$ , and  $c$  are  $250 \text{ mm}$ ,  $500 \text{ mm}$ , and  $200 \text{ mm}$ , respectively. A load  $P$  acts at point  $C$ .

If the angle of rotation of the bar due to the action of the load  $P$  is limited to  $3^\circ$ , what is the maximum permissible load  $P_{\max}$ ?

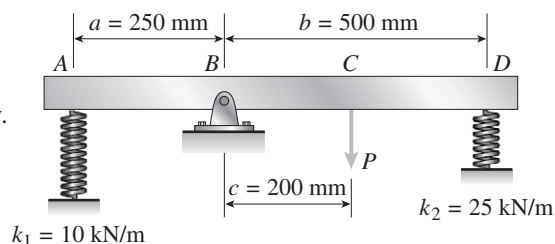

### Solution 2.4-14 Rigid bar supported by springs

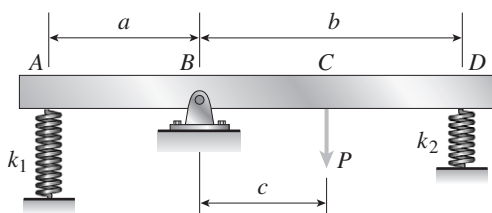

#### NUMERICAL DATA

$$a = 250 \text{ mm}$$

$$b = 500 \text{ mm}$$

$$c = 200 \text{ mm}$$

$$k_1 = 10 \text{ kN/m}$$

$$k_2 = 25 \text{ kN/m}$$

$$\theta_{\max} = 3^\circ = \frac{\pi}{60} \text{ rad}$$

#### FREE-BODY DIAGRAM AND DISPLACEMENT DIAGRAM

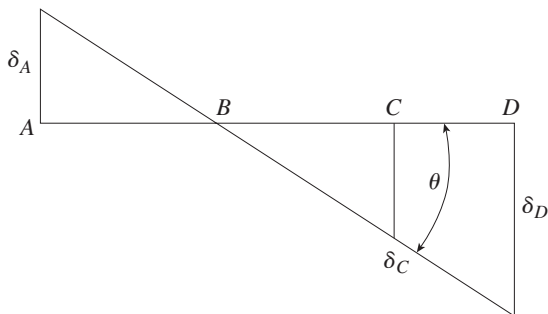
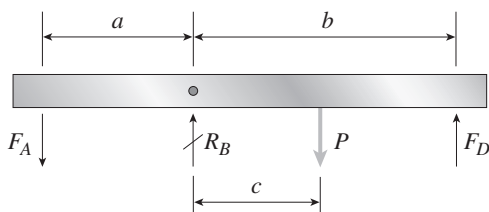

#### EQUATION OF EQUILIBRIUM

$$\sum M_B = 0 \quad \curvearrowright \quad F_A(a) - P(c) + F_D(b) = 0 \quad (\text{Eq. 1})$$

#### EQUATION OF COMPATIBILITY

$$\frac{\delta_A}{a} = \frac{\delta_D}{b} \quad (\text{Eq. 2})$$

#### FORCE-DISPLACEMENT RELATIONS

$$\delta_A = \frac{F_A}{k_1} \quad \delta_D = \frac{F_D}{k_2} \quad (\text{Eqs. 3, 4})$$

#### SOLUTION OF EQUATIONS

Substitute (3) and (4) into Eq. (2):

$$\frac{F_A}{ak_1} = \frac{F_D}{bk_2} \quad (\text{Eq. 5})$$

SOLVE SIMULTANEOUSLY EQS. (1) AND (5):

$$F_A = \frac{ack_1P}{a^2k_1 + b^2k_2} \quad F_D = \frac{bck_2P}{a^2k_1 + b^2k_2}$$

#### ANGLE OF ROTATION

$$\delta_D = \frac{F_D}{k_2} = \frac{bcP}{a^2k_1 + b^2k_2} \quad \theta = \frac{\delta_D}{b} = \frac{cP}{a^2k_1 + b^2k_2}$$

#### MAXIMUM LOAD

$$P = \frac{\theta}{c} (a^2k_1 + b^2k_2)$$

$$P_{\max} = \frac{\theta_{\max}}{c} (a^2k_1 + b^2k_2) \quad \leftarrow$$

SUBSTITUTE NUMERICAL VALUES:

$$\begin{aligned} P_{\max} &= \frac{\pi/60 \text{ rad}}{200 \text{ mm}} [(250 \text{ mm})^2(10 \text{ kN/m}) \\ &\quad + (500 \text{ mm})^2(25 \text{ kN/m})] \\ &= 1800 \text{ N} \quad \leftarrow \end{aligned}$$

**Problem 2.4-15** A rigid bar  $AB$  of length  $L = 66$  in. is hinged to a support at  $A$  and supported by two vertical wires attached at points  $C$  and  $D$  (see figure). Both wires have the same cross-sectional area ( $A = 0.0272$  in.<sup>2</sup>) and are made of the same material (modulus  $E = 30 \times 10^6$  psi). The wire at  $C$  has length  $h = 18$  in. and the wire at  $D$  has length twice that amount. The horizontal distances are  $c = 20$  in. and  $d = 50$  in.

- (a) Determine the tensile stresses  $\sigma_C$  and  $\sigma_D$  in the wires due to the load  $P = 340$  lb acting at end  $B$  of the bar.  
 (b) Find the downward displacement  $\delta_B$  at end  $B$  of the bar.

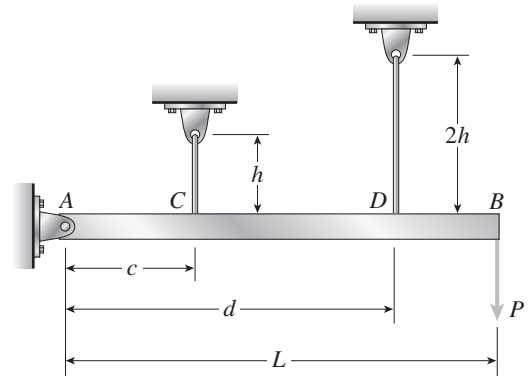

**Solution 2.4-15 Bar supported by two wires**

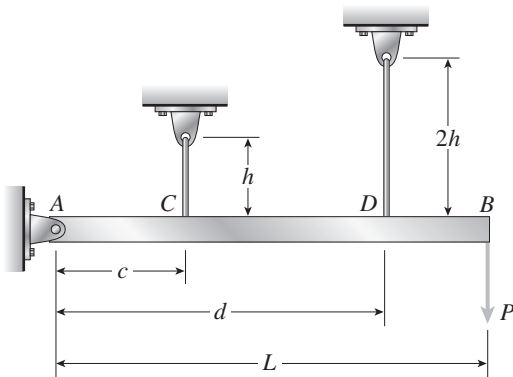

- $h = 18$  in.  
 $2h = 36$  in.  
 $c = 20$  in.  
 $d = 50$  in.  
 $L = 66$  in.  
 $E = 30 \times 10^6$  psi  
 $A = 0.0272$  in.<sup>2</sup>  
 $P = 340$  lb

FREE-BODY DIAGRAM

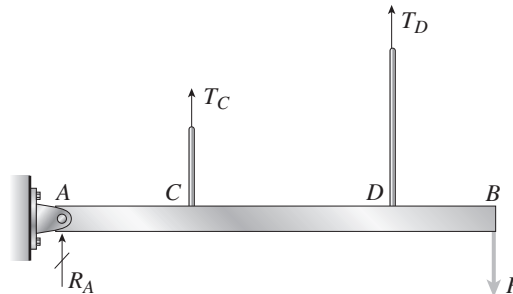

DISPLACEMENT DIAGRAM

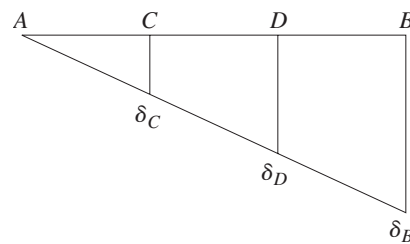

EQUATION OF EQUILIBRIUM

$$\sum M_A = 0 \quad \curvearrowright \quad T_C(c) + T_D(d) = PL \quad (\text{Eq. 1})$$

EQUATION OF COMPATIBILITY

$$\frac{\delta_C}{c} = \frac{\delta_D}{d} \quad (\text{Eq. 2})$$

FORCE-DISPLACEMENT RELATIONS

$$\delta_C = \frac{T_C h}{EA} \quad \delta_D = \frac{T_D(2h)}{EA} \quad (\text{Eqs. 3, 4})$$

SOLUTION OF EQUATIONS

Substitute (3) and (4) into Eq. (2):

$$\frac{T_C h}{cEA} = \frac{T_D(2h)}{dEA} \quad \text{or} \quad \frac{T_C}{c} = \frac{2T_D}{d} \quad (\text{Eq. 5})$$

TENSILE FORCES IN THE WIRES

Solve simultaneously Eqs. (1) and (5):

$$T_C = \frac{2cPL}{2c^2 + d^2} \quad T_D = \frac{dPL}{2c^2 + d^2} \quad (\text{Eqs. 6, 7})$$

TENSILE STRESSES IN THE WIRES

$$\sigma_C = \frac{T_C}{A} = \frac{2cPL}{A(2c^2 + d^2)} \quad (\text{Eq. 8})$$

$$\sigma_D = \frac{T_D}{A} = \frac{dPL}{A(2c^2 + d^2)} \quad (\text{Eq. 9})$$

DISPLACEMENT AT END OF BAR

$$\delta_B = \delta_D \left( \frac{L}{d} \right) = \frac{2hT_D}{EA} \left( \frac{L}{d} \right) = \frac{2hPL^2}{EA(2c^2 + d^2)} \quad (\text{Eq. 10})$$

SUBSTITUTE NUMERICAL VALUES

$$2c^2 + d^2 = 2(20 \text{ in.})^2 + (50 \text{ in.})^2 = 3300 \text{ in.}^2$$

$$(a) \quad \sigma_C = \frac{2cPL}{A(2c^2 + d^2)} = \frac{2(20 \text{ in.})(340 \text{ lb})(66 \text{ in.})}{(0.0272 \text{ in.}^2)(3300 \text{ in.}^2)}$$

$$= 10,000 \text{ psi} \quad \leftarrow$$

$$\sigma_D = \frac{dPL}{A(2c^2 + d^2)} = \frac{(50 \text{ in.})(340 \text{ lb})(66 \text{ in.})}{(0.0272 \text{ in.}^2)(3300 \text{ in.}^2)}$$

$$= 12,500 \text{ psi} \quad \leftarrow$$

$$(b) \quad \delta_B = \frac{2hPL^2}{EA(2c^2 + d^2)}$$

$$= \frac{2(18 \text{ in.})(340 \text{ lb})(66 \text{ in.})^2}{(30 \times 10^6 \text{ psi})(0.0272 \text{ in.}^2)(3300 \text{ in.}^2)}$$

$$= 0.0198 \text{ in.} \quad \leftarrow$$

**Problem 2.4-16** A trimetallic bar is uniformly compressed by an axial force  $P = 40 \text{ kN}$  applied through a rigid end plate (see figure). The bar consists of a circular steel core surrounded by brass and copper tubes. The steel core has diameter 30 mm, the brass tube has outer diameter 45 mm, and the copper tube has outer diameter 60 mm. The corresponding moduli of elasticity are  $E_s = 210 \text{ GPa}$ ,  $E_b = 100 \text{ GPa}$ , and  $E_c = 120 \text{ GPa}$ .

Calculate the compressive stresses  $\sigma_s$ ,  $\sigma_b$ , and  $\sigma_c$  in the steel, brass, and copper, respectively, due to the force  $P$ .

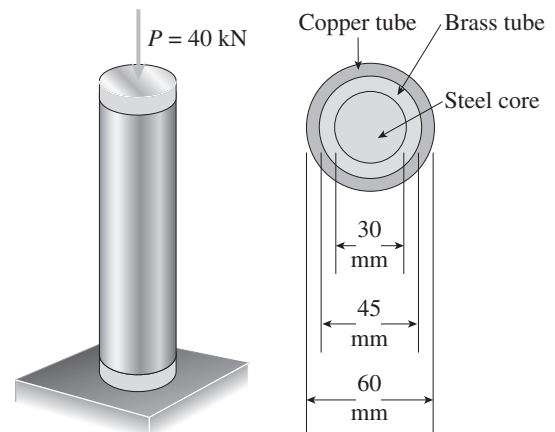

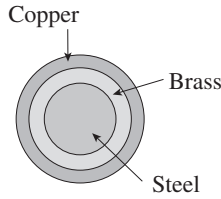
**Solution 2.4-16 Trimetallic bar in compression**

$P_s$  = compressive force in steel core

$P_b$  = compressive force in brass tube

$P_c$  = compressive force in copper tube

FREE-BODY DIAGRAM OF RIGID END PLATE

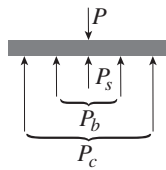

EQUATION OF EQUILIBRIUM

$$\Sigma F_{\text{vert}} = 0 \quad P_s + P_b + P_c = P \quad (\text{Eq. 1})$$

EQUATIONS OF COMPATIBILITY

$$\delta_s = \delta_b \quad \delta_c = \delta_s \quad (\text{Eqs. 2})$$

FORCE-DISPLACEMENT RELATIONS

$$\delta_s = \frac{P_s L}{E_s A_s} \quad \delta_b = \frac{P_b L}{E_b A_b} \quad \delta_c = \frac{P_c L}{E_c A_c} \quad (\text{Eqs. 3, 4, 5})$$

SOLUTION OF EQUATIONS

Substitute (3), (4), and (5) into Eqs. (2):

$$P_b = P_s \frac{E_b A_b}{E_s A_s} \quad P_c = P_s \frac{E_c A_c}{E_s A_s} \quad (\text{Eqs. 6, 7})$$

SOLVE SIMULTANEOUSLY EQS. (1), (6), AND (7):

$$P_s = P \frac{E_s A_s}{E_s A_s + E_b A_b + E_c A_c}$$

$$P_b = P \frac{E_b A_b}{E_s A_s + E_b A_b + E_c A_c}$$

$$P_c = P \frac{E_c A_c}{E_s A_s + E_b A_b + E_c A_c}$$

COMPRESSIVE STRESSES

Let  $\Sigma EA = E_s A_s + E_b A_b + E_c A_c$

$$\sigma_s = \frac{P_s}{A_s} = \frac{PE_s}{\Sigma EA} \quad \sigma_b = \frac{P_b}{A_b} = \frac{PE_b}{\Sigma EA}$$

$$\sigma_c = \frac{P_c}{A_c} = \frac{PE_c}{\Sigma EA}$$

SUBSTITUTE NUMERICAL VALUES:

$$P = 40 \text{ kN} \quad E_s = 210 \text{ GPa}$$

$$E_b = 100 \text{ GPa} \quad E_c = 120 \text{ GPa}$$

$$d_1 = 30 \text{ mm} \quad d_2 = 45 \text{ mm} \quad d_3 = 60 \text{ mm}$$

$$A_s = \frac{\pi}{4} d_1^2 = 706.86 \text{ mm}^2$$

$$A_b = \frac{\pi}{4} (d_2^2 - d_1^2) = 883.57 \text{ mm}^2$$

$$A_c = \frac{\pi}{4} (d_3^2 - d_2^2) = 1237.00 \text{ mm}^2$$

$$\Sigma EA = 385.238 \times 10^6 \text{ N}$$

$$\sigma_s = \frac{PE_s}{\Sigma EA} = 21.8 \text{ MPa} \quad \leftarrow$$

$$\sigma_b = \frac{PE_b}{\Sigma EA} = 10.4 \text{ MPa} \quad \leftarrow$$

$$\sigma_c = \frac{PE_c}{\Sigma EA} = 12.5 \text{ MPa} \quad \leftarrow$$

## Thermal Effects

**Problem 2.5-1** The rails of a railroad track are welded together at their ends (to form continuous rails and thus eliminate the clacking sound of the wheels) when the temperature is 60°F.

What compressive stress  $\sigma$  is produced in the rails when they are heated by the sun to 120°F if the coefficient of thermal expansion  $\alpha = 6.5 \times 10^{-6}/^\circ\text{F}$  and the modulus of elasticity  $E = 30 \times 10^6$  psi?

### Solution 2.5-1 Expansion of railroad rails

The rails are prevented from expanding because of their great length and lack of expansion joints.

Therefore, each rail is in the same condition as a bar with fixed ends (see Example 2-7).

The compressive stress in the rails may be calculated from Eq. (2-18).

$$\Delta T = 120^\circ\text{F} - 60^\circ\text{F} = 60^\circ\text{F}$$

$$\sigma = E\alpha(\Delta T)$$

$$= (30 \times 10^6 \text{ psi})(6.5 \times 10^{-6}/^\circ\text{F})(60^\circ\text{F})$$

$$\sigma = 11,700 \text{ psi} \quad \leftarrow$$

**Problem 2.5-2** An aluminum pipe has a length of 60 m at a temperature of 10°C. An adjacent steel pipe at the same temperature is 5 mm longer than the aluminum pipe.

At what temperature (degrees Celsius) will the aluminum pipe be 15 mm longer than the steel pipe? (Assume that the coefficients of thermal expansion of aluminum and steel are  $\alpha_a = 23 \times 10^{-6}/^\circ\text{C}$  and  $\alpha_s = 12 \times 10^{-6}/^\circ\text{C}$ , respectively.)

### Solution 2.5-2 Aluminum and steel pipes

INITIAL CONDITIONS

$$L_a = 60 \text{ m}$$

$$T_0 = 10^\circ\text{C}$$

$$L_s = 60.005 \text{ m}$$

$$T_0 = 10^\circ\text{C}$$

$$\alpha_a = 23 \times 10^{-6}/^\circ\text{C}$$

$$\alpha_s = 12 \times 10^{-6}/^\circ\text{C}$$

FINAL CONDITIONS

Aluminum pipe is longer than the steel pipe by the amount  $\Delta L = 15$  mm.

$\Delta T =$  increase in temperature

$$\delta_a = \alpha_a(\Delta T)L_a \quad \delta_s = \alpha_s(\Delta T)L_s$$

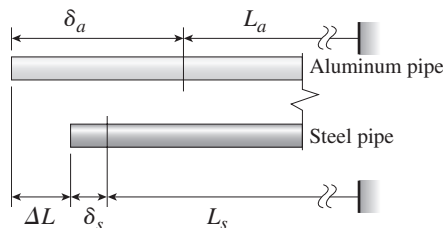

From the figure above:

$$\delta_a + L_a = \Delta L + \delta_s + L_s$$

$$\text{or, } \alpha_a(\Delta T)L_a + L_a = \Delta L + \alpha_s(\Delta T)L_s + L_s$$

Solve for  $\Delta T$ :

$$\Delta T = \frac{\Delta L + (L_s - L_a)}{\alpha_a L_a - \alpha_s L_s} \quad \leftarrow$$

Substitute numerical values:

$$\alpha_a L_a - \alpha_s L_s = 659.9 \times 10^{-6} \text{ m}/^\circ\text{C}$$

$$\Delta T = \frac{15 \text{ mm} + 5 \text{ mm}}{659.9 \times 10^{-6} \text{ m}/^\circ\text{C}} = 30.31^\circ\text{C}$$

$$T = T_0 + \Delta T = 10^\circ\text{C} + 30.31^\circ\text{C}$$

$$= 40.3^\circ\text{C} \quad \leftarrow$$